

# Off-Highway/Utility Engine Testing

Automotive

using the LogBook/360™

Application Note #71

## Application Summary

Small gasoline-powered engines intended for utility vehicles, golf carts, and garden or lawn tractors are typically designed, built, and emissions calibrated at the factory, but they need to be fine tuned in the field to fit each application. The one or two-cylinder engines that reside in this category usually range from four to 29 hp and are first characterized on a dynamometer bench to verify torque, horsepower, emissions, and overall performance. But the loads they encounter while mounted on a vehicle impose more rigorous conditions. The engines must survive shock, vibration, and other dynamics for a predictable life cycle. Kawasaki Motors Corp., USA, manufactures a comprehensive family of such engines, and their Grand Rapids, Mich., facility field-tests and fine-tunes the engines while mounted in a wide variety of vehicles. Each one is instrumented to record engine load, rpm, fuel consumption, temperature, pressure, and air/fuel ratios, simultaneously.

Greg Knott, Senior Application Engineer at the Kawasaki Small Engine Div. Lab, finds that air/fuel ratios and engine speed under load are the most critical indicators of engine behavior. He measures oxygen content at the output of the oxygen sensors located in the exhaust manifold and translates the data to an accurate measure of the intake air/fuel ratio.

Knott tests single-cylinder and twin-V cylinder engines, both air cooled and liquid cooled. He supports some R & D and manufacturing efforts, but primarily analyzes warranty issues and works with customers during the initial installation of engines in their vehicles. The pre-production vehicles include utility vehicles, riding lawnmowers, and commercial walk-behind mowers made by leading commercial manufacturers such as John Deere and Toro. The data acquisition equipment Knott needs to make these measurements must be rugged enough to survive relatively rough treatment while mounted on lawn and garden tractors, operate from the vehicle battery, and provide accurate data.

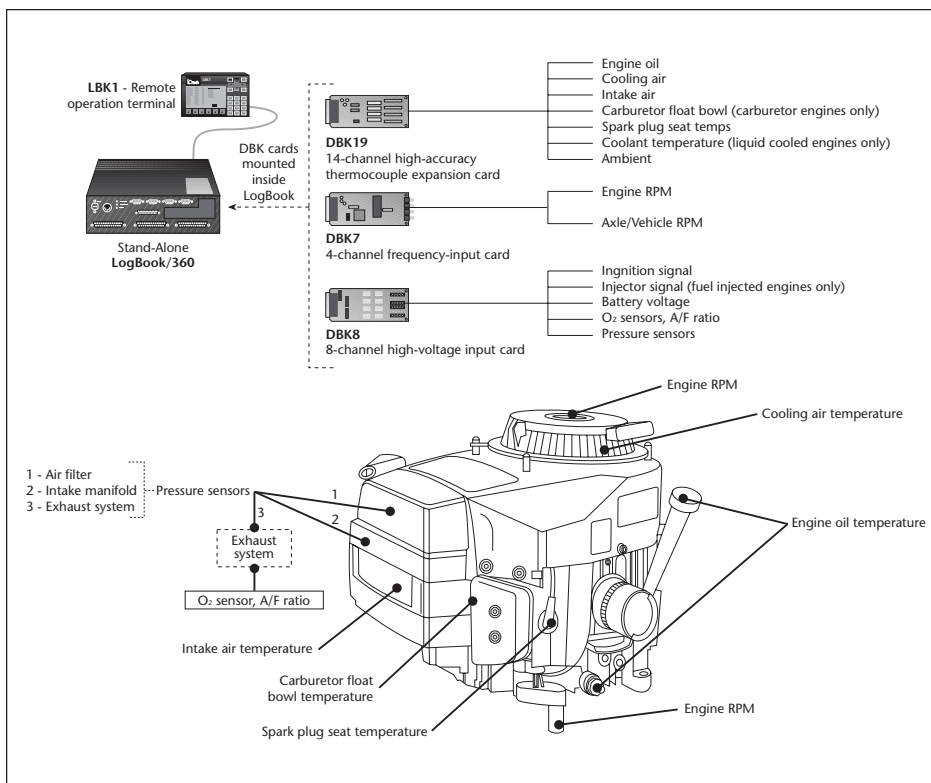

## Potential Solution

When Knott first joined the lab, he used an existing data acquisition system to collect the data he needed, but it had one outstanding limitation, measurements at a rate of only one sample every two seconds. The unit is small and portable, but the low sampling rate cannot provide critical information contained in the rpm data stream such as surging and drooping under field operating conditions. In addition, its accuracy often was not sufficient for many other measurements, such as pressure and spark plug profiles. Says Knott, "When we are just measuring temperature, or another variable with limited dynamic range, then it's fine. But when we want to observe and record engine surges or fluctuating rpm, we don't have the accuracy or mobility to do that with this data acquisition system."

## IOtech's Solution

Knott's predecessor had evaluated other data acquisition systems and eventually purchased an IOtech LogBook/360™. Although Knott wasn't trained in its use, he learned how to set it up and program it in only two days — with no more help than the user's manual. "It's extremely easy to set up, switch between tests, and make changes to software and hardware. You

*Kawasaki designs and manufactures a family of small, carbureted and fuel-injected engines for a wide variety of off-highway vehicles. The Small Engine Div. Lab in Grand Rapids, Mich., uses IOtech LogBook data acquisition systems to field-test and fine-tune the engines in its customers' pre-production vehicles. The most critical measurements that indicate effective and efficient operation include air/fuel ratios and engine speed under load.*



www.iotech.com

can input voltages and it automatically calculates the specific unit of measure you need. What's more, the LogBook's sampling frequency is pretty amazing compared to the others; we run very large sampling rates, from 4 to 6 kHz."

Knott's primary concerns deal with installed engine emissions and cooling. The original emissions work is done in Japan, but a problem often crops up when he installs an engine after having initially set the emissions on the bench. "We have to adjust the emissions differently when it finally goes in a tractor," says Knott. "Also, because we experience a lot of different air flows depending on the design of the hood, deck, or engine cover, we check the air flow in the tractor to make certain the cooling flow is sufficient and not obstructed or limited in any way." Before Knott had the IOtech LogBook, he couldn't drive the machine while observing the engine speed under either full or partial load. But now he can trace the rpm and watch the engine perform. With the rpm take-off set to 200 or 1000 Hz, Knott can see if it is drooping or surging. "I can drive 500 miles on the tractor, and I don't have to be plugged into the wall outlet anymore," Says Knott.

Knott also measures air/fuel ratio, temperature, and pressure with the LogBook. The oxygen sensor measures O<sub>2</sub> content, and by virtue of a software package, converts it to air/fuel ratio. The O<sub>2</sub> sensor's output signal passes through a signal conditioner and then connects to the LogBook. The conditioner converts the O<sub>2</sub> content to a voltage directly proportional to the A/F ratio. "So I plug a formula into the LogBook and an internal function automatically converts the voltage directly to the new unit of measure, air/fuel ratio," says Knott.

Knott also measures numerous temperatures. For example, he instrumented a tractor recently for oil temperature, cooling-air temperature, and ambient temperature. He also frequently monitors the coolant temperature of a liquid-cooled engine and the fuel temperature near the

carburetor. He looks at temperatures at the spark plugs, intake manifold, exhaust, cooling air, and a variety of other areas, depending on the engine type.

The high sample rate is essential not only to rpm, but voltage measurements on the fuel injection systems. Knott can trace all spark plug firings, 3600 times per minute. He sees the spark plug wave shape containing 4 or 5 critical points and the signal through the grounding system when killing the engine by grounding the spark plug.

## Conclusion

Kawasaki engineers use the LogBook/360s to fine tune small gasoline engines for individual applications that include lawn and garden tractors and mowers from four to 29 hp. Each installation requires rpm, air/fuel ratio, and cooling air temperature measurements to ensure the engine performs optimally for its intended use. The LogBook provides more than sufficient accuracy, dynamic range, mobility, and ease of use required for the tests.

## LogBook

The LogBook™ combines on-board intelligence and a large capacity PC-Card removable memory, with the industry's easiest and most powerful data logging software. Its 16-bit, 100-kHz A/D and triggering capabilities make it ideal for collecting high *and* low speed phenomena. A comprehensive array of signal conditioning expansion cards and modules are offered that allow the LogBook to take measurements from virtually any transducer, from thermocouples to accelerometers.

### Features

- Operates without a PC at the test site
- 16-bit, 100-kHz analog and digital sampling
- Compact yet expandable architecture can accommodate over 400 channels of analog, digital, and frequency I/O
- Stand-alone nonvolatile storage of over 250 million samples via removable PC-Card memory
- Card swapping and uploading during acquisition allows continuous data acquisition
- Communication with PC via RS-232, parallel port, modem, or by transporting a PC-Card; optional RS-422 interface
- Built-in analog inputs support 14 programmable ranges up to 20V
- Synchronous, mixed signal acquisition of analog, digital, and counter inputs
- Optional modem support provides remote communication
- Optional GPS support (LogBook/360 only) logs location information
- Optional control terminal provides channel inspection, and acquisition queries
- AC or DC powerable

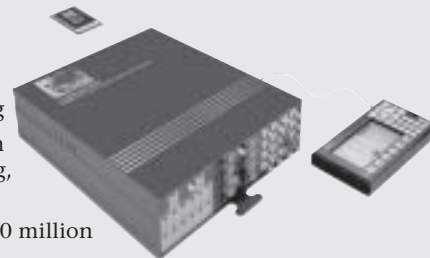

### Software

- Includes LogView™ *Out-of-the-Box*™ software for easy setup, calibration, & more; no programming required
- Simple spreadsheet-style interface provides powerful setup features for immediate startup
- Acquisition configurations can be transported to the LogBook via PC-Card, serial port, parallel port, or modem connection
- Provides direct support for a wide variety of transducers
- Includes eZ-PostView™ for post-acquisition data viewing

DBK7™, DBK8™, DBK19™, eZ-PostView™, LBK1™, LogBook/360™, LogView™, and *Out-of-the-Box*™ are the property of IOtech; all other trademarks and tradenames are the property of their respective holders. 030702.